

Installation Guide

For DC Electric Thruster Models
SE210



SLEIPNER AS

P.O. Box 519

N-1612 Fredrikstad

Norway

www.sleipnergroun.com

DOCUMENT ID: 2663

REVISION: 22

DATE: 2021

LANGUAGE: EN

MI

Contents

Installation Manual

Responsibility of the installer	3
Thruster Measurements	4
Thruster Specifications	5
Technical Specifications	5
Positioning of the tunnel / thruster	6
Tunnel Length	7
Tunnel installation in sail boats	8
Water Deflection	9
Tunnel ends	10
Tunnel installation	11 - 12
Stern tunnel installation	13
Gear Leg & Motor Bracket Installation	14
Propeller Installation	15
Motor Installation	16
Thruster Electrical Installation	17
Electrical Specifications	18
Technical Wiring Diagram	19 - 20
Control Panel Cable Installation	21
Control Panel Installation	22
Pre-delivery Checklist	23
Service and Support.....	24
Product Spare Parts and Additional Resources.....	24
Warranty Statement.....	24

Products

SE210/250TC - SE210 Tunnel thruster, 24V



Sleipner Motor AS
P.O. Box 519, Arne Svendsensgt. 6-8
N-1612 Fredrikstad, Norway

MC_0020

Failure to follow the considerations and precautions can cause serious injury, damage and will render all warranties given by Sleipner Motor as VOID.

MC_0411

Responsibility of the Installer

MC_0038

The installer must read this document to ensure necessary familiarity with the product before installation.

Instructions in this document cannot be guaranteed to comply with all international and national regulations. It is the responsibility of the installer to follow all applicable international and national regulations when installing Sleipner products.

The recommendations given in this document are guidelines ONLY, and Sleipner strongly recommends that advice is obtained from a person familiar with the particular vessel and applicable regulations.

This document contains general installation instructions intended to support experienced installers. If you are not skilled in this type of work, please contact professional installers for assistance.

If required by local regulation, electrical work must be done by a licensed professional.

Appropriate health and safety procedures must be followed during installation.

Faulty installation of Sleipner products will render all warranties given by Sleipner Motor AS.

General Installation Considerations and Precautions for Thrusters

MC_0425

- Do not install the thruster in a position where you need to cut a stiffener/ stringer/ support that may jeopardise the hull integrity without checking with the boat builder this can be done safely.
- We advise painting the gear house and propellers with anti-fouling. **(NB: Do not paint the anodes, sealing, rubber fittings or propeller shafts)**
- Do not finish the inside of the tunnel with a layer of gel-coat/ topcoat or similar. There is only room for a thin coat of primer and two layers of anti-fouling between the tunnel and the props.
- Never run the thruster out of water.
- The electro/ hydraulic motor must be handled with care. Do not place down the motor on the drive shaft.

General Installation Considerations and Precautions for Electric Thrusters

MC_0031

- The thruster must NOT be installed in compartments that require ignition proof electric equipment. If necessary, make a separate compartment. **(NB: Ignition Protected systems are tested to be installed in areas with possible explosive gases in accordance with ISO 8846)**
- When installing the thruster electro motor in small compartments, ensure the compartment is well ventilated to allow for cooling of the electro motor.
- If the height of the room you are installing the thruster is limited, the thruster can be installed horizontally or at any angle in-between.
 - If the electro motor is positioned more than 30 degrees off vertical, it must be supported separately.
 - Beware of keeping installation within advised measurements. No part of the propeller or gear house must be outside the tunnel.
- Do not install the thruster in a position where you need to cut a stiffener/ stringer/ support that may jeopardise the hull integrity without checking with the boat builder this can be done safely.
- The electro motor, components and cables must be mounted so they remain dry at all times.
- We advise painting the gear house and propellers with anti-fouling. **(NB: Do not paint the anodes, sealing, rubber fittings or propeller shafts)**
- Do not finish the inside of the tunnel with a layer of gel-coat/ topcoat or similar. There is only room for a thin coat of primer and two layers of anti-fouling between the tunnel and the props.
- Don't install the electro motor close to easily flammable objects or equipment as it will reach over 100°C before the temperature switch is activated.
- Do not store items close to the thruster motor. Any loose items near the thruster motor is a potential fire hazard and can cause undesired short-circuiting.
- Do not lift it by internal cable connections, main terminals.
- The thruster power supply circuit must include the recommended sized fuse and a battery isolation switch.

General Installation Considerations and Precautions for DC Electric Motors

MC_0426

- The electro motor will generate some carbon dust so any storage compartments must be separated from the thruster to prevent nearby items becoming dusty/ dirty. **(NB: IP version motors generate dust but are enclosed.)**

Measurement code	Measurement description	*210 24v	
		mm	inch
ID	Internal tunnel diameter	250	9,84
H	Motor Height	480	18,90
W	Width	337	13,27
L	Length	274	10,79
WD	Water Depth	250	9,84
TL	Minimum tunnel length	273	10,75
TL (recommended)	Recommended tunnel length	323	12,72
T (min)	Minimum tunnel wall thickness	7	0,28
T (max)	Maximum tunnel wall thickness	9	0,35

*Valid for SE & SEP

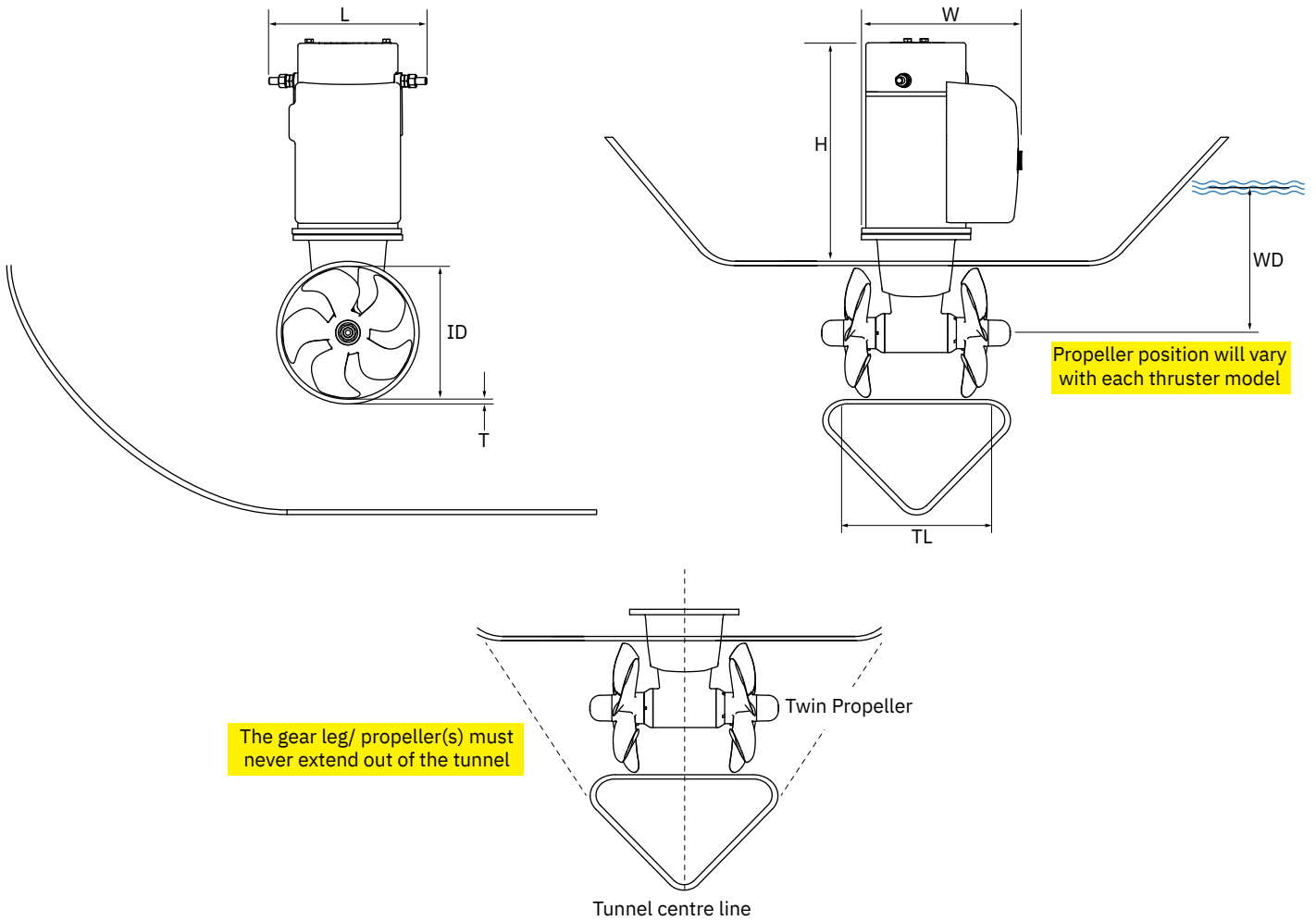

MG_0075

Description	* 210
Available DC System (v)	24v
Thrust 12v or 24v (kg * lbs)	250 kg * 550 lbs
Thrust 10.5v or 21v (kg * lbs)	210 kg * 462 lbs
Typical Boat Size (m * ft)	17m - 24m * 55ft - 78ft
Propulsion System	Twin Counter Rotating
Power (kw * Hp)	10kw * 13.15hp
Weight (kg * lbs)	68kg * 150lbs

*Valid for SE / SE IP & SEP / SEP IP

Technical Specifications

- Motor:** Custom made reversible DC-motor.
- Gear house:** Seawater resistant bronze. Ball-bearing at propeller shaft and a combination of ball bearing and slide bearing at drive shaft. (Pre-filled and sealed for life)
- Motor bracket:** Seawater resistant aluminium, galvanically insulated from the motor..
- Tunnel:** Cross spun with rowing G.R.P tunnel
Steel & aluminium tunnels available at request.
- Propeller:** 5-blade skewback “Q-prop” propeller, fibreglass reinforced composite.
- Batteries:** Minimum recommended battery capacity (cold crank capacity by DIN/SAE standard)
Contact a battery supplier for more information.
- Max. use:** 2 - 3 min. duty cycle at 20°C
- Safety features:**
- Electronic time-lapse device protects against sudden change of drive direction.
 - The electric thermal cut-off switch in electro motor protects against overheating (auto-reset when electro motor cools down).
 - Flexible coupling between electro-motor and drive shaft protects electro motor and gear system if propeller jams.
 - Original Sleipner panels shut off automatically 6 minutes after last use. This interval can be adjusted in 5 min steps up to 60 minutes or turned off completely.
 - Original Sleipner panels use child-safe double ON buttons.
 - An integrated microprocessor monitors solenoids, reduce wear and risk of solenoid lock-in.
 - Auto-stop of the thruster occurs when an undesirable solenoid lock-in occurs or when continuous operation cut-off timer exceeds 3 minutes.

Aim to install the thruster as far forward as possible (1)

Due to the leverage effect around the boats' pivot point. The distance difference from the boat pivots' point to the thruster will determine the amount of real rotation power for the boat.

Aim to install the thruster as deep as possible under the waterline (2)

Deeper installations prevent air from being sucked into the tunnel from the surface, resulting in reduced thrust performance and increase noise levels during operation. Deeper installations increase water pressure for maximum efficiency from the thruster.

The centre of the tunnel should be a minimum of 1 x the tunnel diameter below the waterline. The installer must make evaluations based on thruster performance, boat type and operating conditions. As a general recommendation, the position of the tunnel should not be a minimum of 1/4 of the diameter of the tunnel from the boat keel. **(NB: This can be overlooked depending on the installation methods defined in this manual.)**

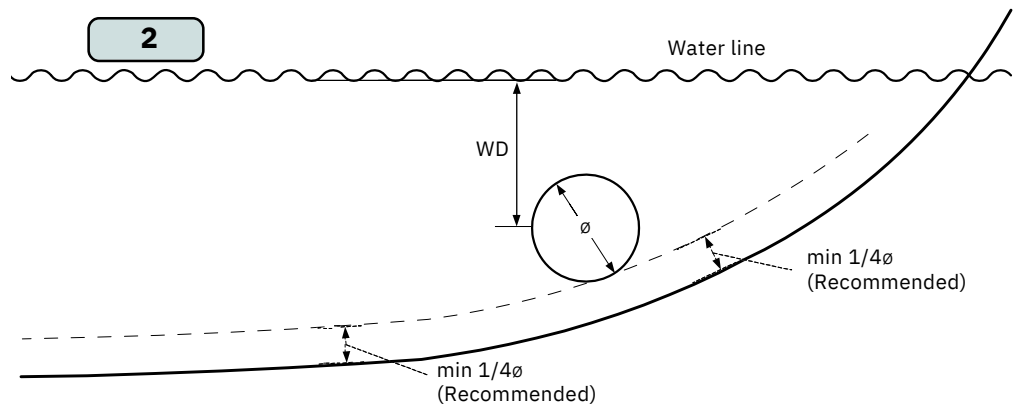
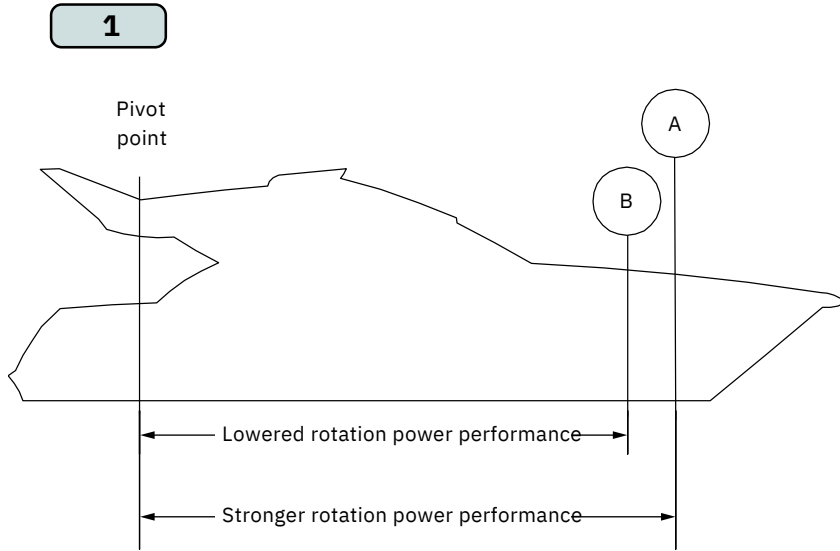

MG_0001

Optimal tunnel length

Achieving the correct tunnel length depends on many factors from the hull type, operation and environmental conditions.

Tunnels should avoid being longer than 4 x the tunnel diameter as this will reduce thruster performance. **(NB: Installing long length tunnels can flex/bend over time and may require additional support. Consult with a naval architect.)**

1. Do not allow the variable length of the tunnel walls to vary in length excessively.
EG. The top tunnel wall is x 4 longer than the bottom wall.
2. If the tunnel is too long, the friction inside will reduce the water speed and thereby the thrust.
3. If the tunnel is too short (typically only in the bottom section of the tunnel) cavitation problems can occur as water flow will not be able to "straighten" itself before reaching the propeller. This cavitation will reduce performance and increase noise during operation.

Thruster within the tunnel

It is important the propellers and the lower unit/ gear leg must be entirely inside the thruster tunnel. Propellers that protrude from the tunnel will not perform as intended.

4. Standard Use

Tunnel length must be long enough to ensure the propellers are not extruding the tunnel.

5. Flat Bottom Hull

Tunnel lengths must be longer than the standard measurement outlined within the manual to ensure a circular vacuum is not created between the thruster and the bottom of the boat.

6. High-Speed Boats

Tunnel lengths must be increased to protect the propeller from damage when crashing against the water surface during high-speed cruising. **(NB: This can include the length of a spoiler)**

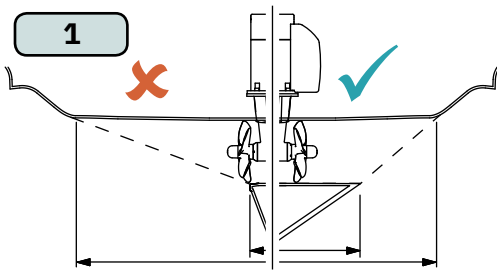

Do not allow the variable length of the tunnel walls to vary in length excessively.
EG. the top tunnel wall is x 4 longer than the bottom wall.

3

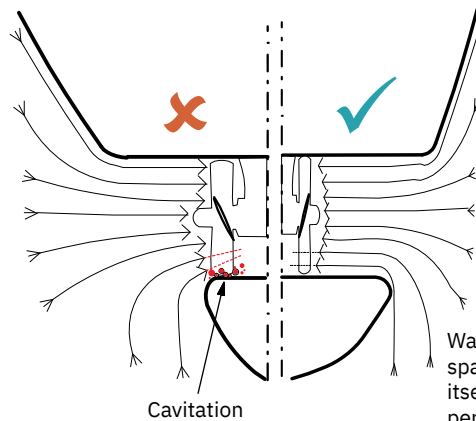

Cavitation

Water flow must have space to "straighten" itself for best performance.

2

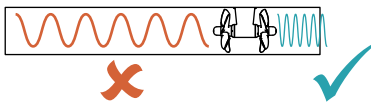

4 STANDARD USE

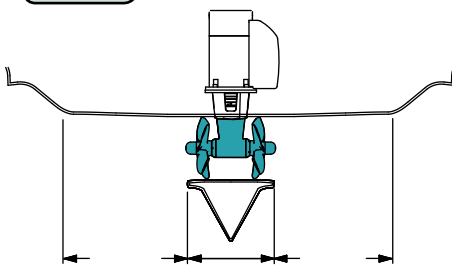

The gear leg/ propeller(s) must never extend out of the tunnel

5 FLAT BOTTOM HULL

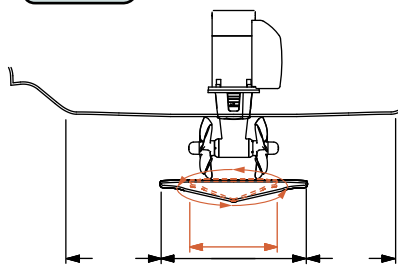

Increase tunnel length to prevent a circular water vacuum cavity between the propeller and the hull of the boat.

6 HIGH-SPEED OPERATION

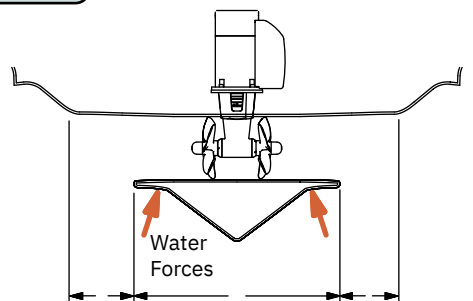

Water Forces

Increase tunnel length to protect the propeller from water forces when high-speed cruising.

MG_0048

Some sail boats have a flat bottom and shallow draft in the bow section. This can make installing the thruster as far forward from the boats main pivot point difficult. **(Fig. 1).**

However, it is possible to install a tunnel thruster in most sail boats, even when the hull does not directly support the fitting of a tunnel.

Instead fit the tunnel halfway into the underneath section of the existing hull. Strengthen it with a deflector/ spoiler directing the water flow around the tunnel. This will allow installation of the thruster in the proper position on the boat, maintaining the reliability and space advantages of the tunnel thruster.

This installation is being used by some of the world's largest sail boat builders and has proven to give little to no speed loss during normal cruising. This can also be an installation method for flat bottomed barges to avoid extremely long tunnels and large oval tunnel openings in the hull.

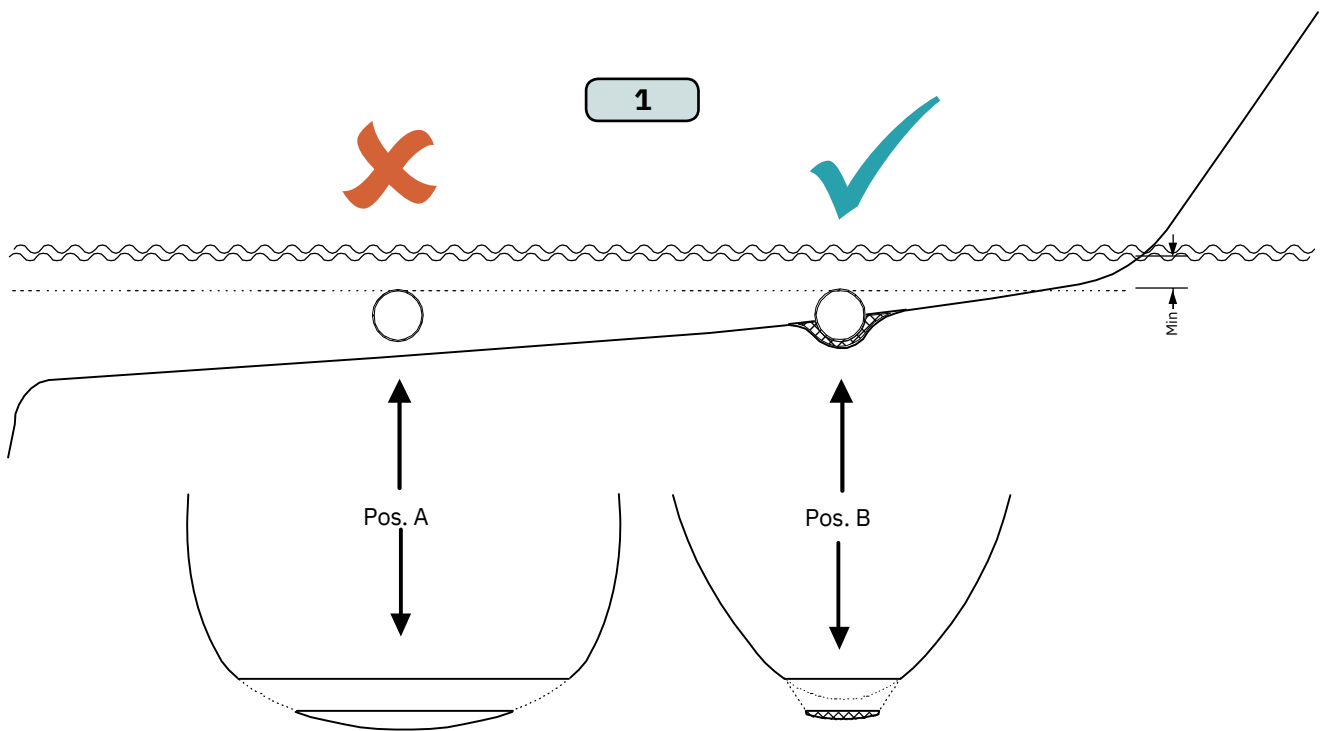

MG_0004

1. A possible problem in sail boats or fast powerboats is that a non-rounded surface can generate drag from the back face of the tunnel, as it creates a "flat" area facing the flow of water.

This problem can be solved in two different ways, depending on what is possible or easier to perform.

2. The best solution which generally reduces the most drag is to make a recess in the hull at the back of the tunnel. As the back face is removed water can flow freely past the tunnel entry. The depth and shape of this recess will depend on the boat and the angle facing up/ down aft of the tunnel insert. Normally it is angled slightly down because of the water flow on this area.
3. Making a deflector/ spoiler in front and underneath the tunnel can also reduce damage to the thruster and drag. The deflector/ spoiler will push the water flow out from the hull so water can pass by the back face of the tunnel. The shape and size of this deflector/ spoiler will depend on the hull shape. The easiest way of making the deflector/ spoiler is to retain a part of the lower forward area of the tunnel while installing the tube. Use this area as support to mould a soft curve/spoiler shape from the hull.
4. The thruster propeller can spin (passively) producing noise while sailing or cruising as water is forced through the tunnel. Water-flow directed through the tunnel at high speeds, during turning or as the boat bumps waves while underway can also damage the thruster.

(NB: As a rule, you should not see the back face of the tunnel when standing directly in front of the boat looking aft.)

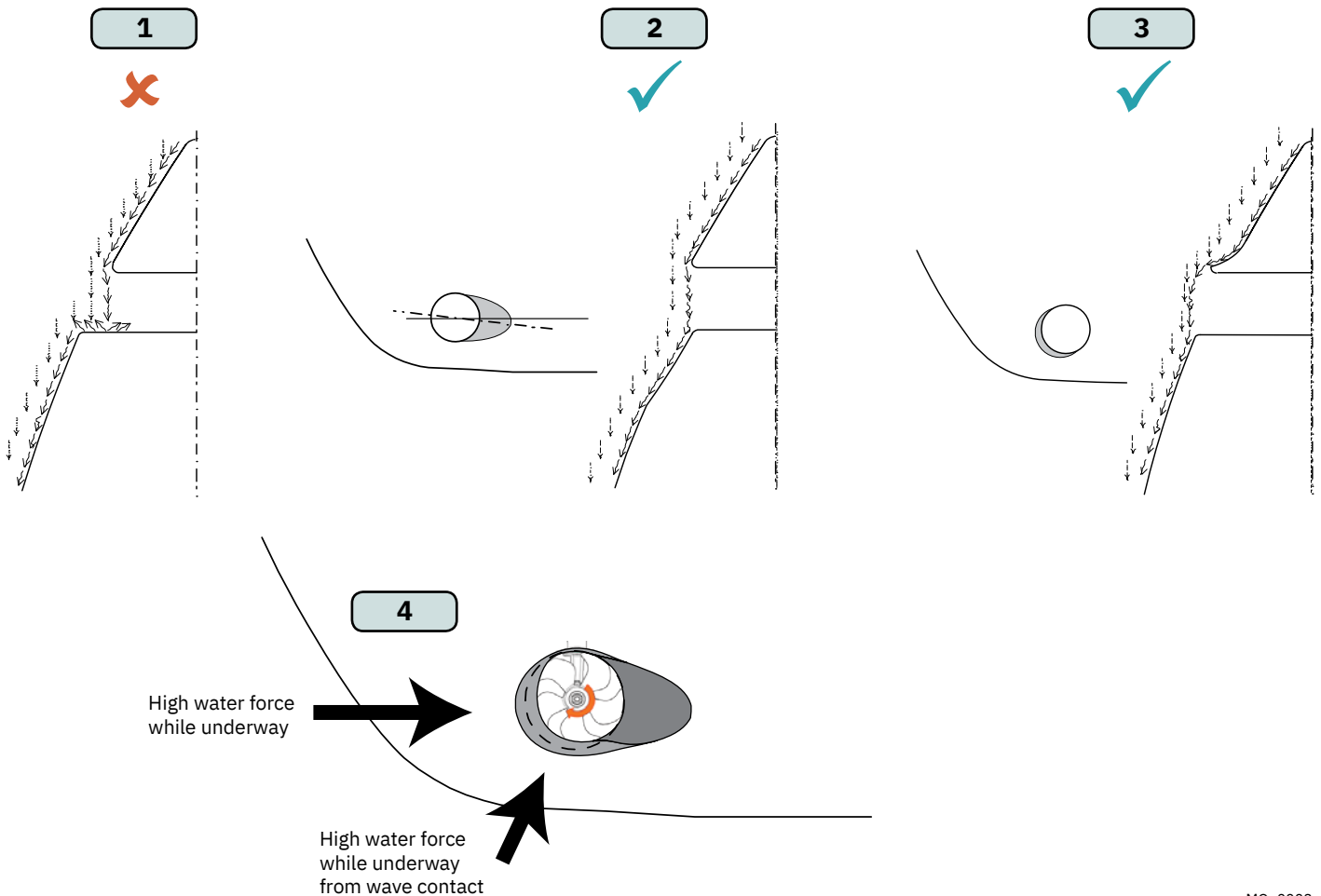

Rounded tunnel ends will maximise thrust and minimise noise and cavitation.

For best performance round the tunnel connection to the hull-side as much as possible. The minimum rounding has a radius of 10% of the diameter of the tunnel.

Significant advantages of a rounded tunnel over a sharp tunnel to hull connections are:

1. A rounded tunnel end will prevent the creation of turbulence/ cavitation created from a sharp tunnel end when water passes by the tunnel.
 - The turbulence/ cavitation will block the outer area of the tunnel and thereby reduces the effective tunnel diameter and thrust.
 - Turbulence/ cavitation on the propeller will lessen the thrusters performance and create excess noise.
2. For steel/ aluminium hulls angled tunnel ends also offer similar performance as a rounded connection.
3. A rounded tunnel end makes the thruster draw water from along the hull-side, creating a vacuum that will suck the boat sideways and thereby give additional thrust.
 - With a sharp tunnel end, the thruster will be unable to take water from along the hull-side, and you will not gain the desired vacuum and additional thrust. This "free" extra thrust in optimal installations be 30 - 40% of the total thrust.

(NB: A Side-power thruster propeller does not produce cavitation at working speed. Therefore, any cavitation and cavitation noise in the tunnel will be caused during improper tunnel installation.)

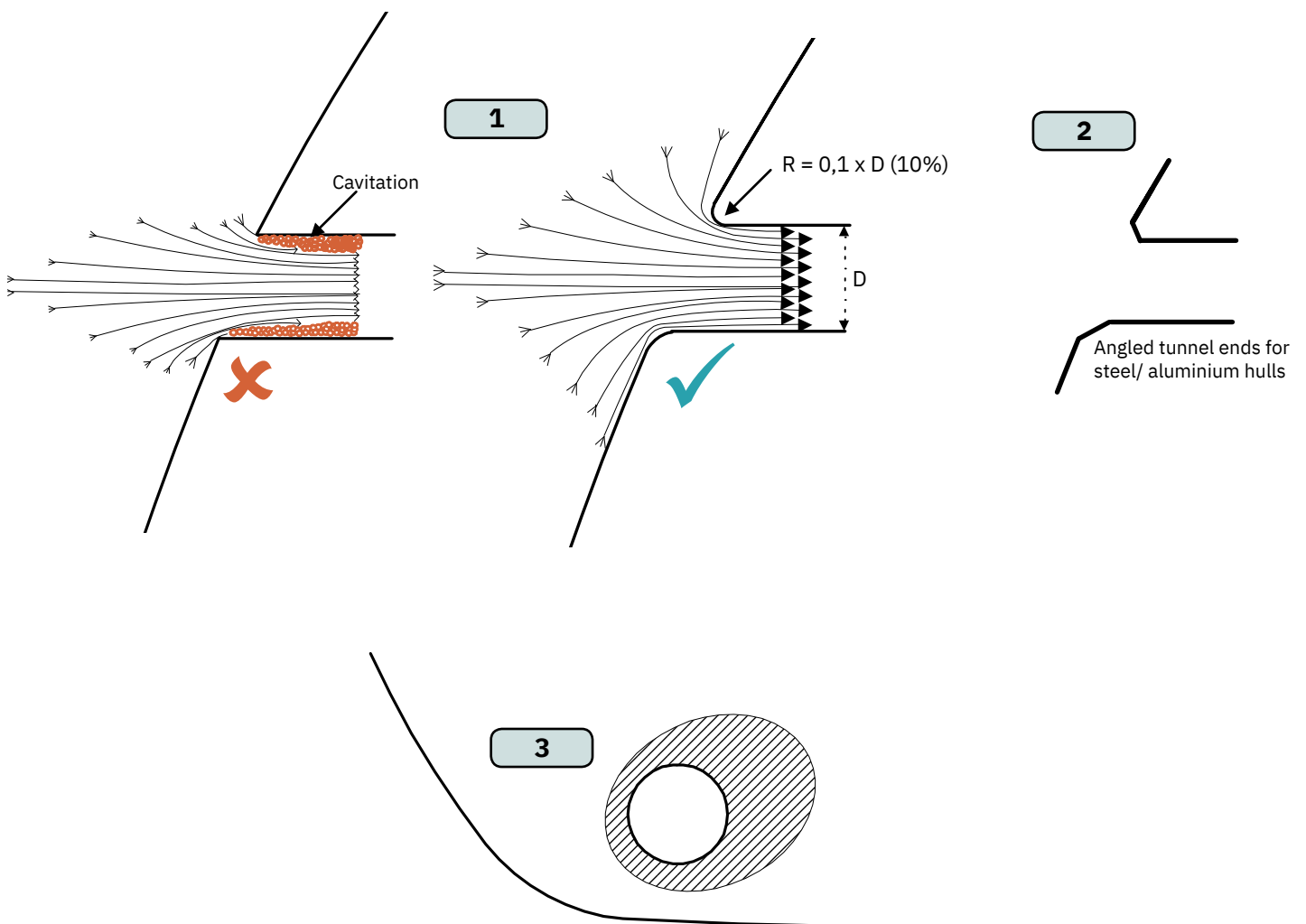

IMPORTANT

We recommend that a professional does the fibreglass, steel or aluminium fitting of the tunnel. These instructions are only general instructions and do not explain in any way the details of fibreglass work. Problems caused by faulty installation of the tunnel, are the installers full responsibility.

1. Find the position in the boat considering the information earlier in this manual and the applicable measurements for the thruster model you are installing. Mark the centre of the tunnel on both sides of the hull. Drill a hole horizontally at these marks.
2. Mark the circle for the tunnel opening (outside diameter of the tunnel) and cut the hole.
3. Grind off the gel coat to the “real fibreglass” area 12cm around the hole on both inside and outside the hull to cast the tunnel to the hull (**Fig. 3**).
4. Insert the tunnel and mark its shape to fit the hull. (**NB: if you are installing with a deflector/ spoiler, leave a part of the tunnel in the front and underside of the tunnel that will cover the back face.**)
5. Cut the tunnel ends to the desired shape and lightly sand its surface. Clean the area with acetone or similar where you are going to apply fibreglass. (**NB: Do not cast or add fibreglass to the area were the thruster will be placed.**)
6. Cast the tunnel to the inside of the hull, use at least eight layers of 300g fibreglass and resin, preferably alternating mat and rowing types of fibreglass. To round the tunnel ends to a 10% radius make further layers inside to preserve the desired hull thickness.

(NB: Ensure gaps between the tunnel and the hull are completely filled with resin/ fibreglass. In areas where you can not access to make layers of resin/ fibreglass, a resin/ fibreglass mixture must be used in that area.)

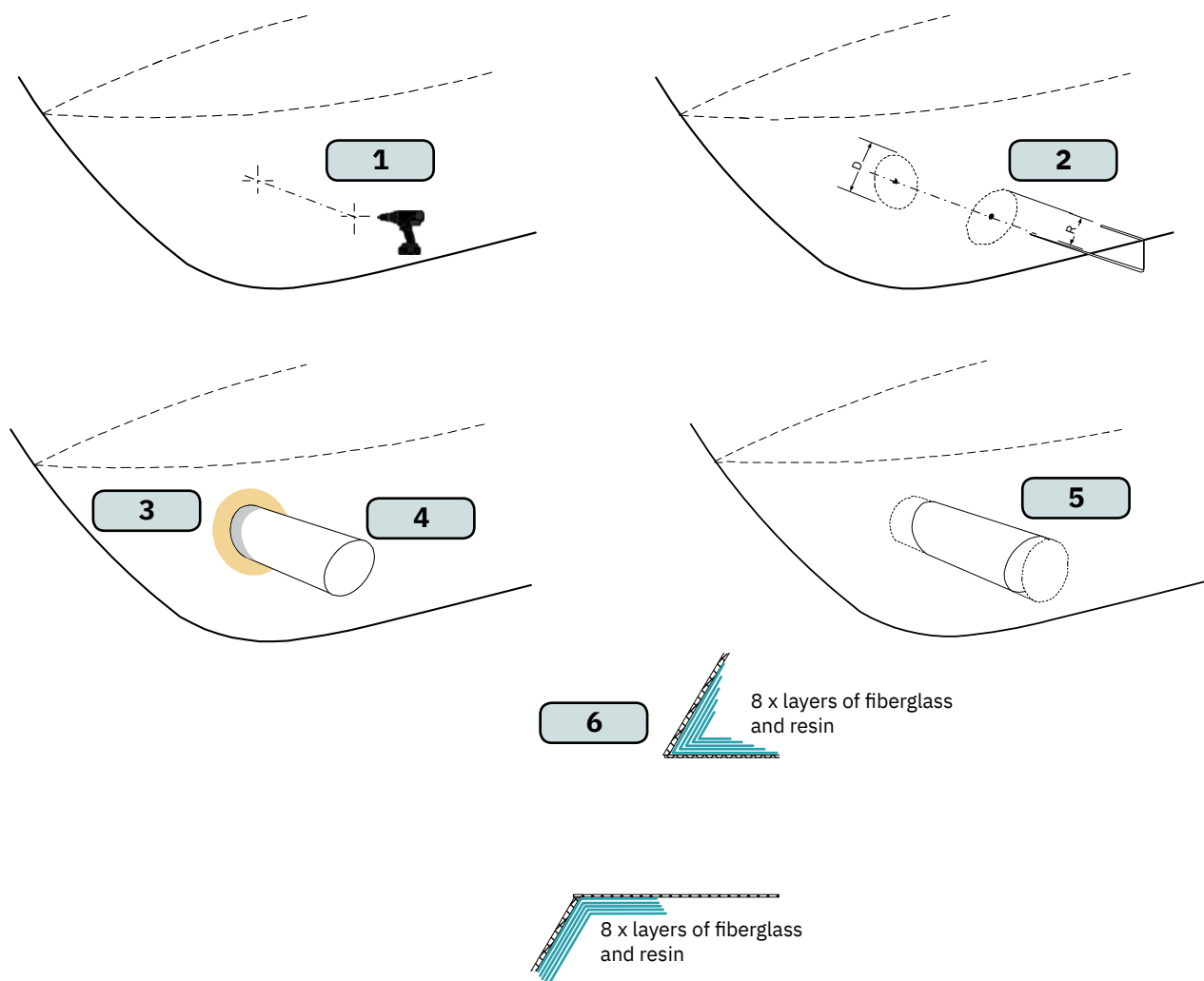

With tunnel installed and cast.

1. Round the edges with a radius of 10% of the tunnel diameter.
2. For steel/ aluminium hulls make a slope with a length of 10-15% of the tunnel diameter.
(NB: If this is not possible, round the tunnel end as much as possible.)
3. Additionally cast two layers on the outside of the tunnel/ hull in a 10cm area
4. Follow the same method if making the deflector/ spoiler.

You must apply gel coat to areas you have grounded/ moulded to make waterproof. These areas allow water access to the hull which is typically not waterproof without these applications outside. **(NB: All original Side-Power tunnels are fully waterproof when delivered except in the areas where you have cut and bonded it to the hull.)**

IMPORTANT
 Avoid all casting where the motor-bracket is to be placed, as this will cause misfit and possible failure to the gear house.

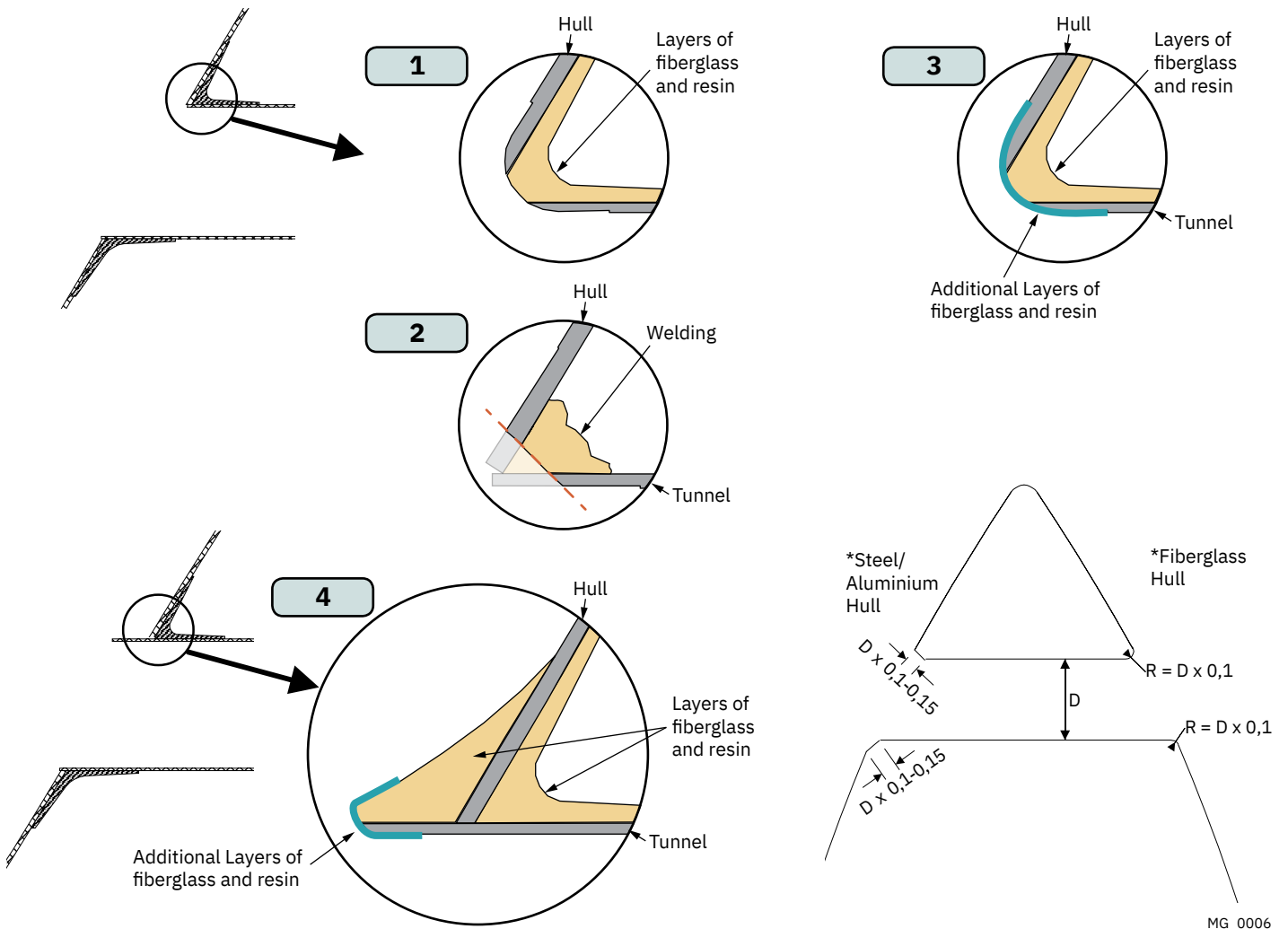

For **Stern Thruster** installation please refer to the supplied manual in your Sleipner product delivery

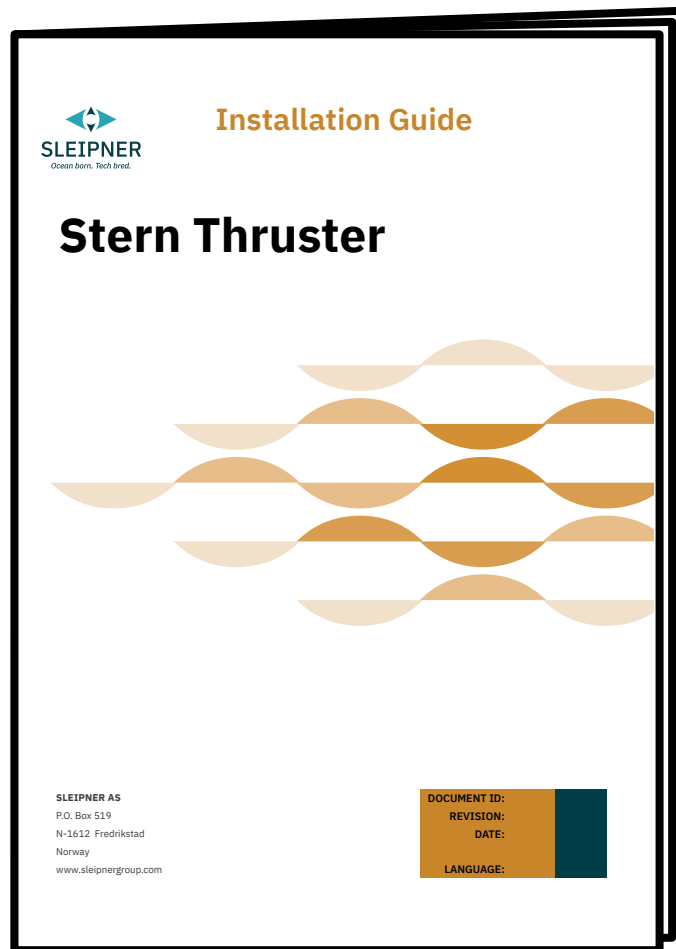

! Please refer to the graphic for special considerations relating to your model !

1. Mark the tunnel centreline and the boat's centreline. **(NB: Install the gear leg and propeller as shown above for the thrust direction to correspond with the control panel. Position gear leg with the P-mark facing port and the S-mark facing starboard.)**
2. Use the gasket or template (recommended) to mark the hole centres and double-check the measurements. The centre hole MUST be placed using the boat centreline as shown above. **(NB: All holes must be in-line with the tunnels' centreline for correct installation, clearance between the propeller and the tunnel is minimal.)**
3. Smooth the surface of the tunnel. A rough surface will cause possible failure/movement of the gear leg. The motor bracket must rest steadily on the tunnel.
4. Drill the main centre hole followed by the two screw-holes.
5. Place the gear leg (without the propeller) with the gasket on inside the tunnel. Place the propeller on the gear leg to ensure it is centred and rotates freely with the same clearance from each blade to the tunnel wall. Place top motor bracket to measure the drive shaft has come through the motor bracket at the correct height. Remove the gear leg and propeller for final installation.
6. Apply appropriate sealant to both sides of the gasket and place on the gear leg. Place the gear leg in the tunnel (without the propeller).
7. Install the top motor bracket and gear leg gently together. Use appropriate sealant to ensure that no leakages occur. **(NB: See your sealant data sheet for the correct application process.)**
8. Fasten the gear leg and the motor bracket with the bolts provided. Fasten to torque as shown above.

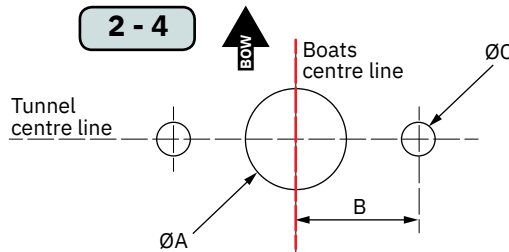
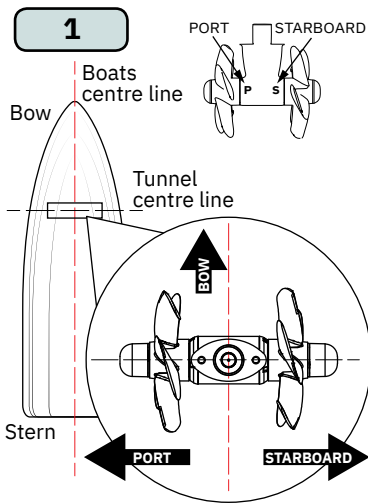

Measurement Description	SE*P*IP 80		SE*P*IP 100		SE*P*IP 120		SE*P*IP 130		SE*P*IP 150		SE*P*IP 170		SE*P*IP 210	
	mm	inch	mm	inch	mm	inch	mm	inch	mm	inch	mm	inch	mm	inch
ØA	34	1.33	47	1.85										
B	28	1.1	40	1.57										
ØC	9	0.35	12	0.43										

*P- Propositional
*IP- Ignition Protected

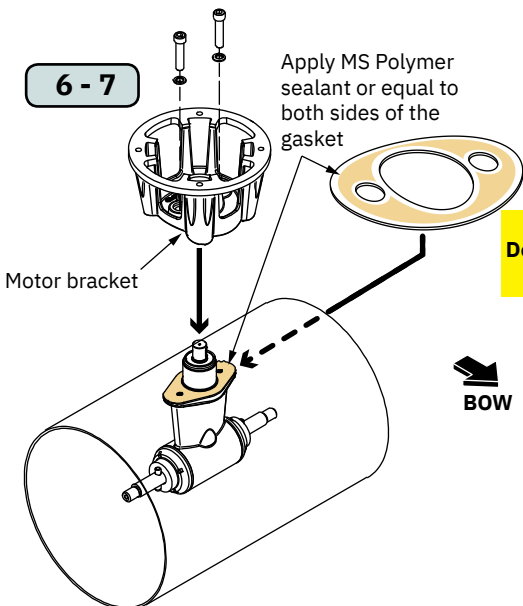
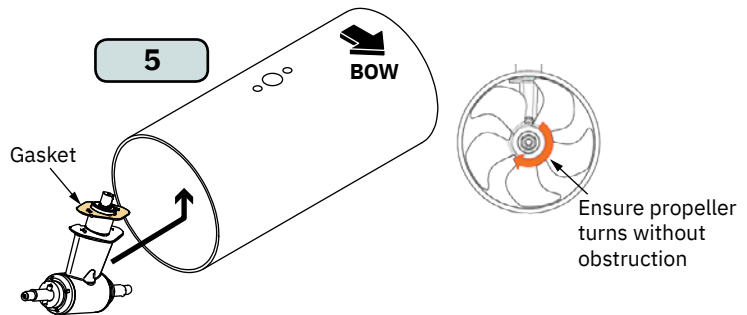

IMPORTANT
Do not apply sealant to the holes.

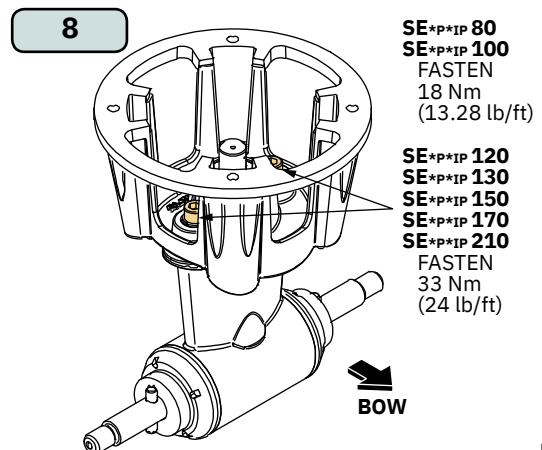

SE*P*IP 80
SE*P*IP 100
FASTEN
18 Nm
(13.28 lb/ft)

SE*P*IP 120
SE*P*IP 130
SE*P*IP 150
SE*P*IP 170
SE*P*IP 210
FASTEN
33 Nm
(24 lb/ft)

! Please refer to the graphic for special considerations relating to your model !

1. Centre the drive pin and Insert the propeller onto the shaft spine. Rotate the propeller until the drive pin aligns with the internal slot in the propeller.

IMPORTANT

For twin counter-rotating gear legs, propellers are marked with P (Port) and S (starboard) and must be installed appropriately.

2. Insert the washer to the end of the shaft spline. Tighten with the propeller lock-nut.
3. Insert the anode to the end of the propeller and tighten the anode holding screw. Apply a thread glue (Loctite 243 or similar) to ensure that the anode holding screw does not unscrew itself from during the rotation of the propeller.
4. Apply anti-fouling to the gear leg and propeller. Do not apply anti-fouling to any rubber elements of the gear leg or anodes.

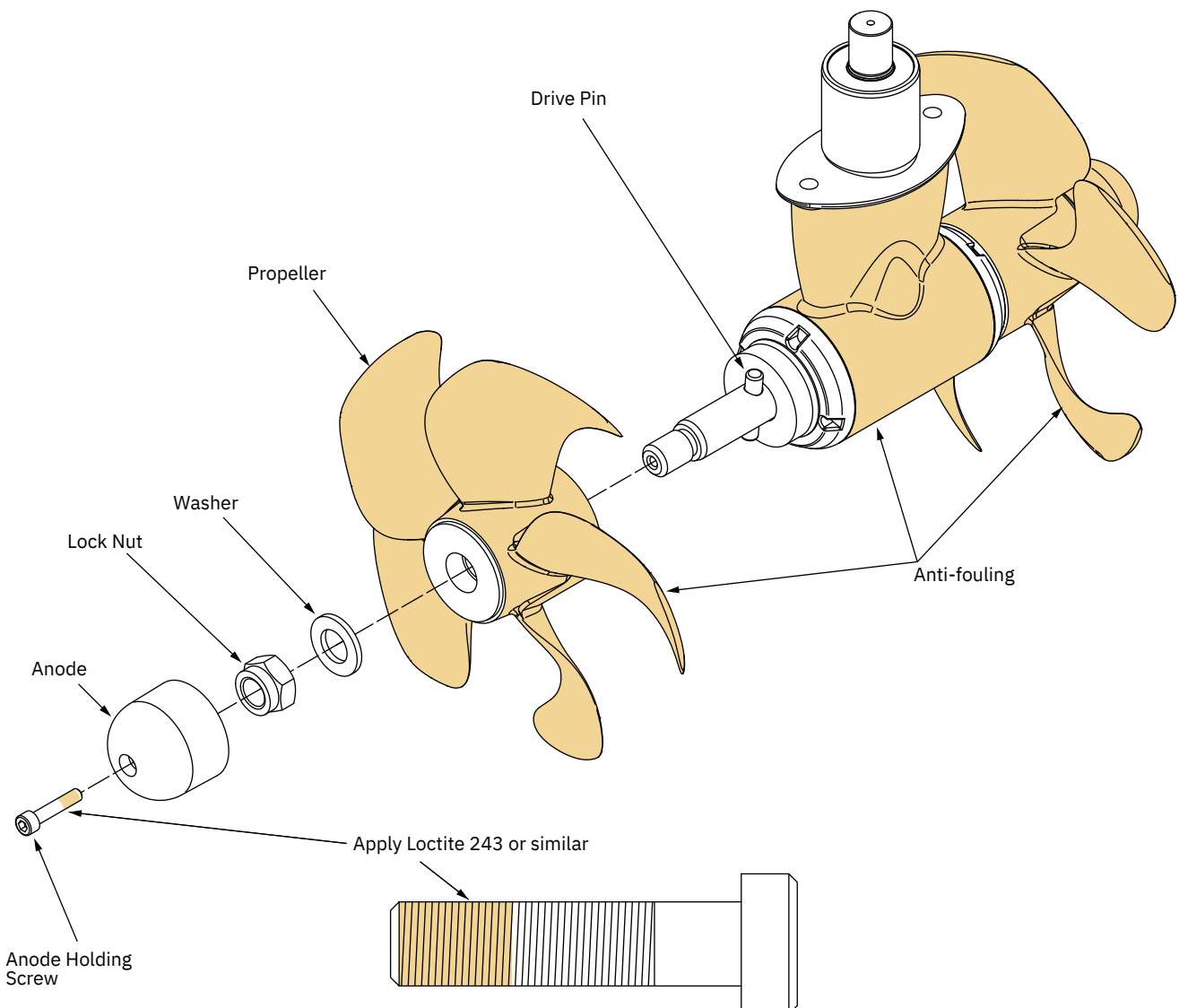

MG_0033

! Please refer to the graphic for special considerations relating to your model !

1. Install the motor onto the motor bracket ensuring the couplings are engaged together correctly (top and bottom). **(NB: The motor can be placed in all directions on the motor bracket. However, ensure the cable terminals are accessible for electrical installation later.)**
2. If you are installing the motor at an angle of more than 30 degrees off vertical, the motor will require separate/ additional support. **(NB: Do not position supports on the motors top cap.)**
3. Fasten the bolts holding the motor to the motor bracket with the above torque.
4. Check the drive shafts are engaged by rotating the propeller. **(NB: Rotating the propellers can be hard due to the gear reduction and the motor, however the propeller must be able to rotate via hand power.)**

IMPORTANT

The thruster motor assembly must be protected using suitable covering to avoid dust/debris ingress from fabrication/maintenance/shipbuilding operations. On completion of operations, the cover must be removed before operating the thruster.

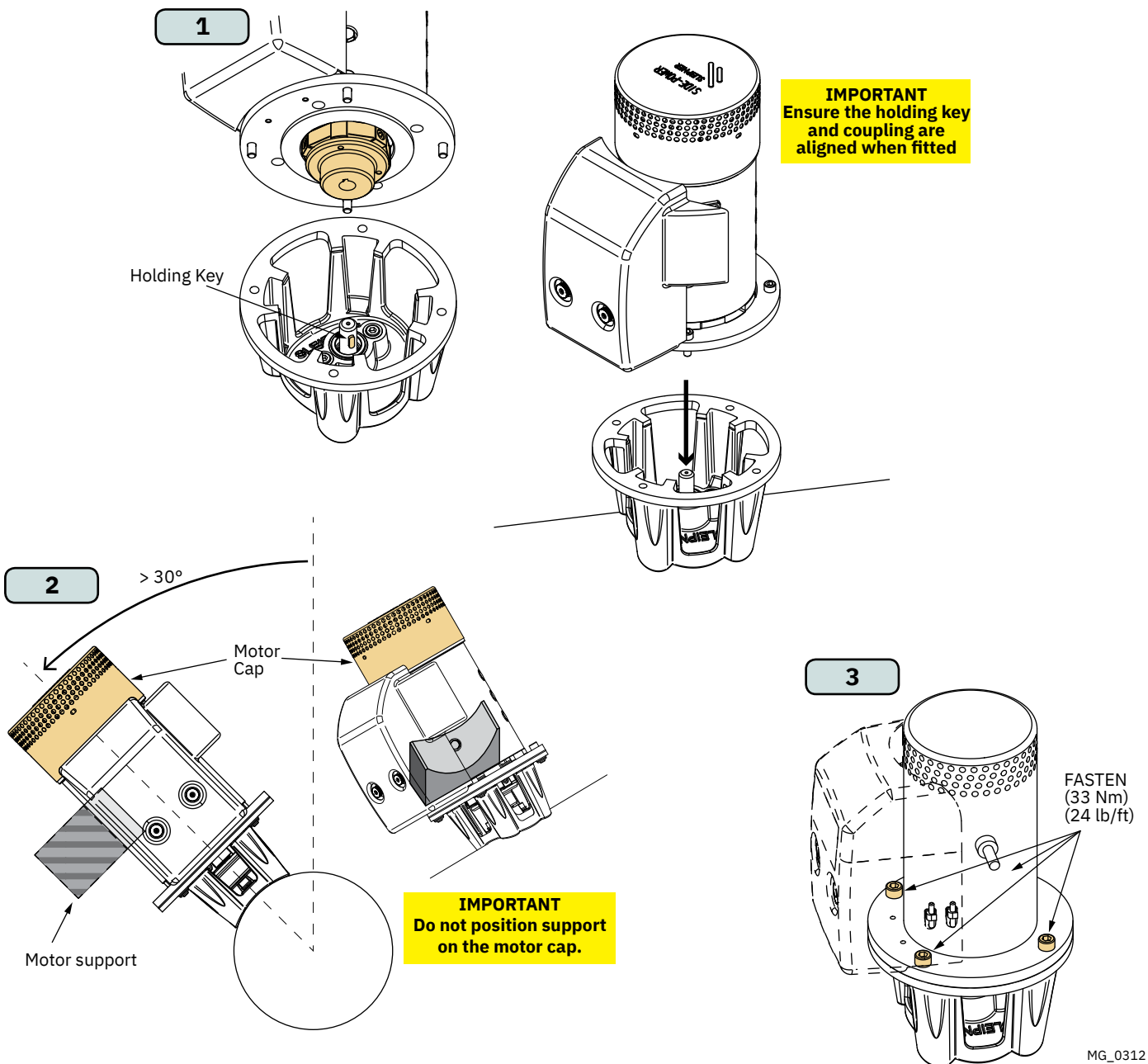

MG_0312

! Please refer to the graphic for special considerations relating to your model !

- Information of electrical table. *see next page*
 - All power cable lengths represent the total length of the combined (+) and (-) cables.
 - Battery capacity is stated as minimum cold crank capacity, (CCA).
 - Use slow blow rated fuses to hold stated Amp-Draw for min. 5 minutes.
 - Consider the AMP hours (Ah) for your specific duty cycle.
- Use appropriate sized cables and batteries with high cranking capacity to feed the thruster. The actual voltage at the motor while running the thruster decides the motors output RPM and thrust. Use larger cables and stronger batteries for better results.
 - See electrical specifications for advised minimum cables and batteries (CCA).
- Install the main switch as close to the battery as possible and ensure the main positive lead can take loads without noticeable voltage drop.
 - Ensure the main switch (battery isolator) can be turned off independently and manually when not on board or in emergencies.
 - Ensure it is easily accessible and update instructions that this should be turned off like the boat's other main switches.

It is advised to install a fuse in the positive lead for protection against short-circuiting.
 - Ensure a slow type and appropriately sized to take the amperage draw for at least 5 minutes.

(NB: For Ignition Protected installations remember to use ignition protected fuses and switches if fitted in areas that require this feature. Ensure to follow your national regulations)

- Cable lugs must have adequate electrical and mechanical isolation and fitted with cable lug covers.
- Fasten cables to the required torque.

WARNING
 Check the following with the main switch is set to off :
 After all electrical connections have been completed check with an ohm meter that there is no electrical connection between
 1. electro-motor flange and the positive terminal on the motor
 2. electro-motor flange and the battery negative terminal on the motor
 If unsure contact skilled personnel.

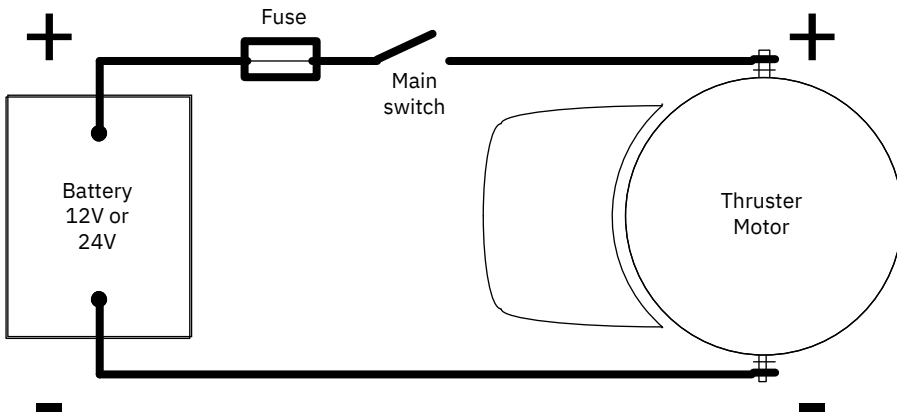

IMPORTANT
 Do NOT use washers between lugs, this causes overheating and fire. Spring washers must be placed in the outer position before tightening the nut.

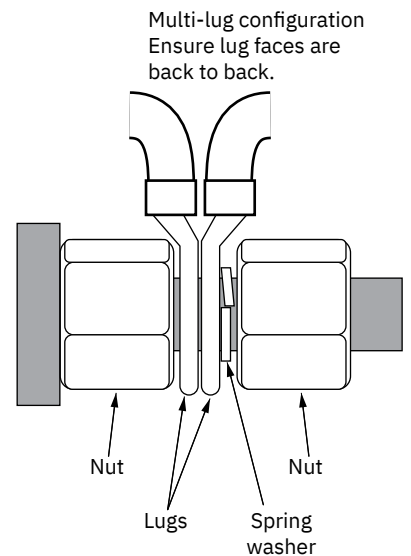
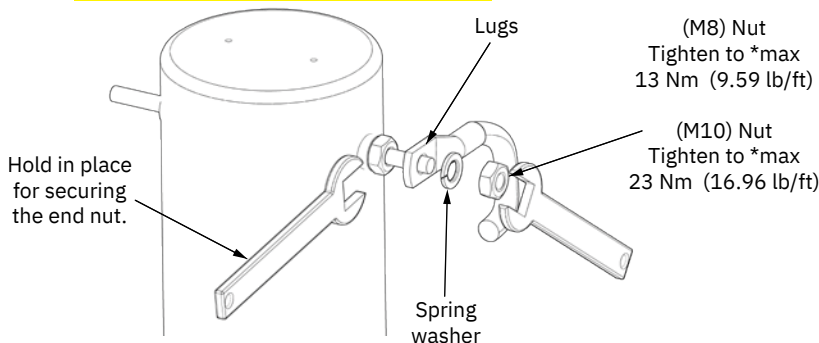

*Valid for DC motors

Model Size	System Voltage	Nominal current draw	Min. battery CCA	Rec. fuse	<7m total + & -		7-14m total + & -		15-21m total + & -		22-28m total + & -		28-35m total + & -		36-45m total + & -		
					Min.	Rec.	Min.	Rec.	Min.	Rec.	Min.	Rec.	Min.	Rec.	Min.	Rec.	
*20/110S	12 V	150 A	DIN: 200 SAE: 380 EN: 330	ANL 150	25	35	35	50	50	70	70	95	95	120	120	2 x 70	
					3	2	2	1/0	1/0	2/0	3/0	3/0	2 x 4/0	2 x 2/0			
*25/110S	12 V	200 A	DIN: 200 SAE: 380 EN: 330	ANL 150	25	35	50	50	70	70	95	95	120	120	2 x 70	2 x 70	
					3	2	1/0	1/0	2/0	3/0	3/0	2 x 2/0	2 x 2/0	2 x 4/0	2 x 2/0		
*30/125S *30/140	12 V	245 A	DIN: 200 SAE: 380 EN: 330	ANL 150	35	50	50	70	70	95	95	120	120	2 x 70	2 x 70	2 x 95	
					2	1/0	1/0	2/0	2/0	3/0	3/0	4/0	2 x 2/0	2 x 2/0	2 x 3/0	2 x 3/0	
*40/125S *40/140	12 V	315 A	DIN: 300 SAE: 570 EN: 520	ANL 250	35	50	70	95	95	120	120	2 x 70	2 x 70	2 x 95	2 x 120	2 x 120	
					2	1/0	2/0	3/0	3/0	4/0	4/0	2 x 2/0	2 x 2/0	2 x 3/0	2 x 3/0	2 x 4/0	2 x 4/0
*50/140S	12 V	370 A	DIN: 350 SAE: 665 EN: 600	ANL 325	50	70	70	95	120	2 x 70	2 x 70	2 x 95	2 x 95	2 x 120	2 x 120	2 x 120	
					1/0	1/0	2/0	3/0	4/0	2 x 2/0	2 x 2/0	2 x 3/0	2 x 3/0	2 x 4/0	2 x 4/0	2 x 4/0	
*60/185S *60/140	24 V	170 A	DIN: 175 SAE: 332 EN: 280	ANL 150	25	25	25	35	35	50	50	50	70	70	70	70	
					3	3	3	2	2	1/0	1/0	2/0	2/0	2/0	2/0	2/0	
*60/185S *60/140	12 V	370 A	DIN: 350 SAE: 665 EN: 600	ANL 325	50	70	70	95	120	2 x 70	2 x 70	2 x 95	2 x 95	2 x 120	2 x 120	2 x 120	
					1/0	1/0	2/0	3/0	4/0	2 x 2/0	2 x 2/0	2 x 3/0	2 x 3/0	2 x 4/0	2 x 4/0	2 x 4/0	
*80/185T	24 V	170 A	DIN: 175 SAE: 332 EN: 280	ANL 150	25	25	25	35	35	50	50	50	70	70	70	70	
					3	3	3	2	2	1/0	1/0	2/0	2/0	2/0	2/0	2/0	
*100/185T	12 V	530 A	DIN: 550 SAE: 1045 EN: 940	ANL 400	70	70	120	2 x 70	2 x 95	2 x 120	2 x 120	2 x 120	2 x 120	2 x 120	2 x 120	2 x 120	
					2/0	2/0	4/0	2 x 2/0	2 x 3/0	2 x 3/0	2 x 4/0	2 x 4/0	2 x 4/0	2 x 4/0	2 x 4/0	2 x 4/0	
*120/215T	24 V	420 A	DIN: 300 SAE: 570 EN: 520	ANL 250	35	35	35	50	50	70	70	95	95	120	120	2 x 95	
					2	2	2	1/0	1/0	2/0	2/0	2/0	2/0	2/0	2/0	2/0	2 x 3/0
*130/250T	12 V	740 A	DIN: 750 SAE: 1425 EN: 1320	ANL 500	95	95	2 x 70	2 x 95	2 x 120	2 x 120	2 x 120	2 x 120	2 x 120	2 x 120	2 x 120	2 x 120	
					3/0	3/0	2 x 2/0	2 x 3/0	2 x 4/0	2 x 4/0	2 x 4/0	2 x 4/0	2 x 4/0	2 x 4/0	2 x 4/0	2 x 4/0	
*150/215T	24 V	340 A	DIN: 400 SAE: 760 EN: 680	ANL 325	50	50	50	70	70	95	95	120	120	120	120	2 x 95	
					1/0	1/0	1/0	2/0	2/0	2/0	2/0	2/0	2/0	2/0	2/0	2/0	2 x 3/0
*170/250	24 V	800 A	DIN: 450 SAE: 855 EN: 760	ANL 325	70	70	70	95	95	120	120	120	120	120	120	2 x 95	
					2/0	2/0	2/0	2/0	2/0	2/0	2/0	2/0	2/0	2/0	2/0	2/0	2 x 3/0
*210/250	12 V	350 A	DIN: 560 SAE: 1064 EN: 940	ANL 500	95	95	2 x 95	2 x 95	2 x 120	2 x 120	2 x 120	2 x 120	2 x 120	2 x 120	2 x 120	2 x 120	
					3/0	3/0	2 x 2/0	2 x 3/0	2 x 4/0	2 x 4/0	2 x 4/0	2 x 4/0	2 x 4/0	2 x 4/0	2 x 4/0	2 x 4/0	
*250/300	24 V	610 A	DIN: 400 SAE: 760 EN: 680	ANL 325	50	50	50	70	70	95	95	120	120	120	120	2 x 95	
					2	1/0	1/0	2/0	2/0	2/0	2/0	2/0	2/0	2/0	2/0	2/0	2 x 3/0
*300/300	24 V	550 A	DIN: 560 SAE: 1064 EN: 940	ANL 400	70	70	70	95	95	120	120	120	120	120	120	2 x 95	
					2/0	2/0	2/0	2/0	2/0	2/0	2/0	2/0	2/0	2/0	2/0	2/0	2 x 3/0
*300/300	24 V	500 A	DIN: 560 SAE: 1330 EN: 940	ANL 400	70	70	70	95	95	120	120	120	120	120	120	2 x 95	
					2/0	2/0	2/0	2/0	2/0	2/0	2/0	2/0	2/0	2/0	2/0	2/0	2 x 3/0
*300/300	24 V	610-670 A	DIN: 700 SAE: 1330 EN: 1170	ANL 500	70	70	95	120	120	120	120	120	120	120	120	2 x 95	
					2/0	2/0	2/0	2/0	2/0	2/0	2/0	2/0	2/0	2/0	2/0	2/0	2 x 3/0
*300/300	24*2	400-450A (48V)	DIN: 400 SAE: 760 EN: 680	ANL 325	50	70	50	70	70	95	95	120	120	120	120	120	NA
					1/0	2/0	1/0	2/0	2/0	2/0	2/0	2/0	2/0	2/0	2/0	2/0	4/0

Technical Wiring Diagram

NB! Very important to check the following with main-switch in off position:

After all electrical connections have been completed check with an ohm meter that there is no electrical connection between electro-motor body and positive terminal on the motor and between the electro motor body and the negative (A1) terminal on the motor. If you feel unsure on how to perform this check, contact skilled personnel for guidance.

NB! Make sure to not use any electronic interface box (delay box) older than the 6 1232i (ex. 6 122x)

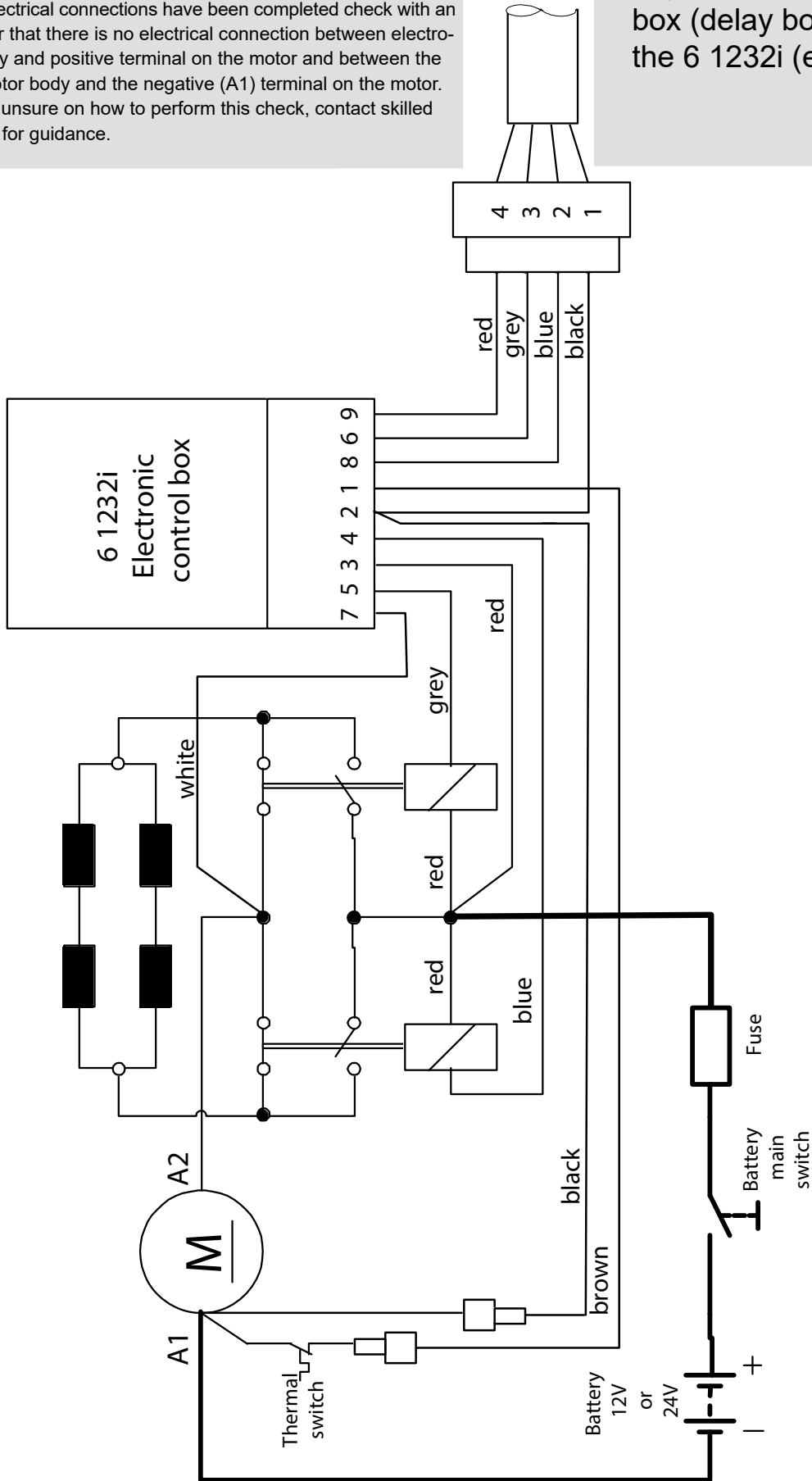

Technical Wiring Diagram

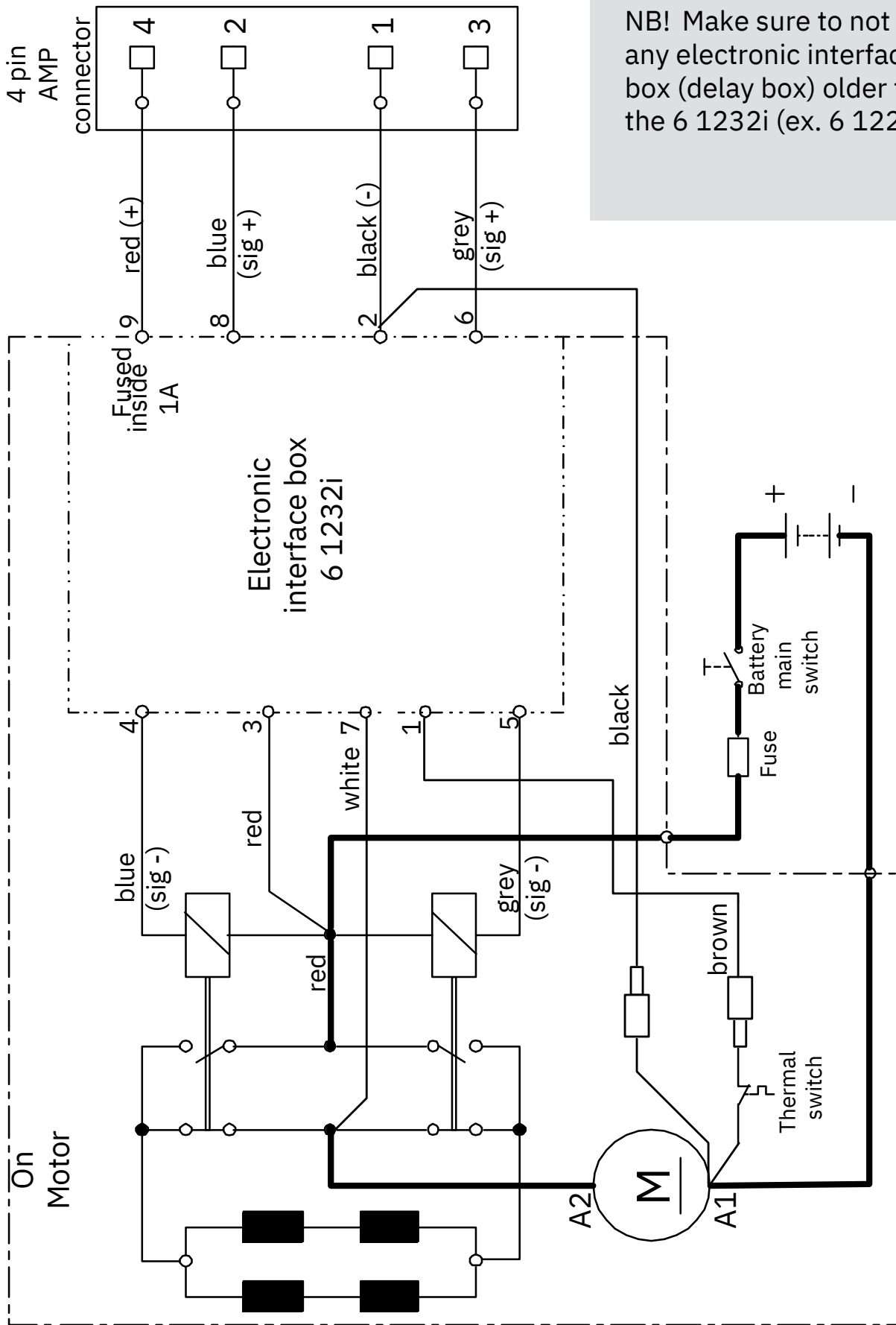

NB! Make sure to not use any electronic interface box (delay box) older than the 6 1232i (ex. 6 122x)

! Please refer to the graphic for special considerations relating to your model !

- All Sleipner control panels can be used in any combination.
- All control panels can be installed using:
 - Y-connectors - for standard on/off
 - T-connectors - for S-Link proportional power system.

(NB: If two or more control panels are operated at the same time in opposite directions, the electronic control box will stop the thruster until it receives a single signal or thrust in one direction.)

- Sleipner on/off equipment it is entirely “plug & play” and require no additional configuration setup.

See the Control panel manual for more information.

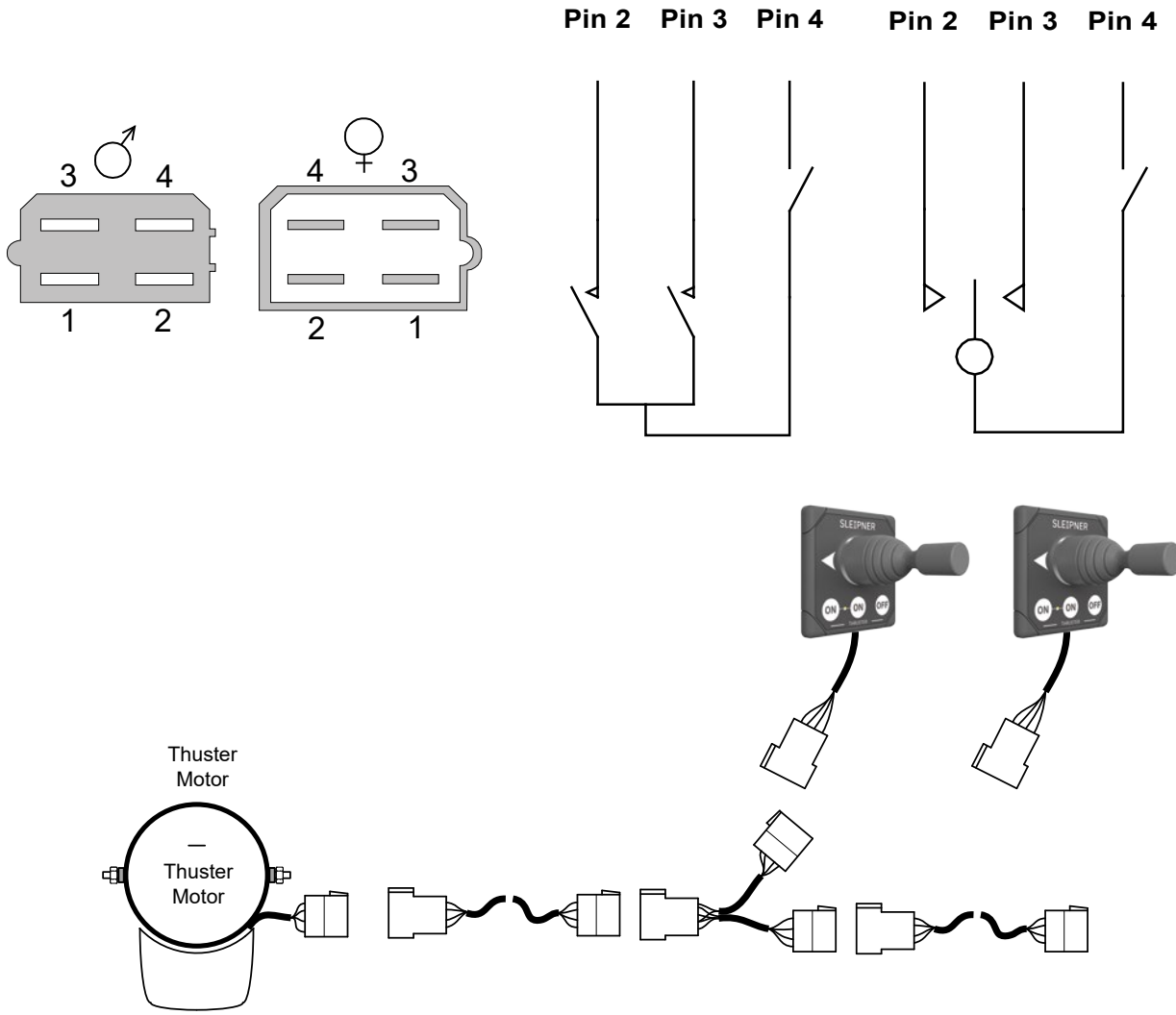

For **Control Panel** installation please refer to the supplied manual in your Sleipner product delivery



- The bolts holding the gear house and motor bracket together are tightened correctly.
- The bolts holding the motor to its bracket are tightened correctly.
- All electrical connections are clean, dry and tight, and the correct cable, fuse and main switch size.
- Check that there is no electrical connection between the electro motor body and positive terminal on the motor, and between the electro motor body and the negative (A1) terminal on the motor with an ohm meter.
- Anti-fouling has been applied to the gear house and propeller but NOT anodes, sealing/ rubber fittings or propeller shafts.
- Propeller is fastened correctly to the shaft.
- Propeller turns freely in tunnel.
- The anode and/ or holding screw is tightened well with thread glue.
- Check the boat for potential water leakage around installation areas.
- Correct drive direction as per control panel.
- User Manual is supplied to the owner.

The thruster has been installed as per the instructions in this manual and all points in checklist above have been controlled.

Signed:

Date:

Thruster type:

Serial number:.....

Date of delivery:.....

Correct drive direction as per control panel:

The compartment for the thruster has been isolated from general bilge water and has no obvious or suspected risks for flooding:

.....
.....
.....

Other comments by installer:

.....
.....

Find your local professional dealer from our certified worldwide network for expert service and support.

visit our website www.sleipnergrou.com/support

Product Spare Parts and Additional Resources

For additional supporting documentation, we advise you to visit our website www.sleipnergrou.com and find your Sleipner product.

Warranty statement

1. Sleipner Motor AS (The "Warrantor") warrants that the equipment (parts, materials and embedded software of products) manufactured by the Warrantor is free from defects in workmanship and materials for the purpose for which the equipment is intended and under normal use and service (the "Warranty").
2. This Warranty is in effect for two years (Leisure Use) or one year (Commercial and other Non-leisure Use) from the date of purchase by the end user (for demonstration vessels, the dealer is deemed as end user).
3. This Warranty is transferable and covers the equipment for the specified warranty period.
4. The warranty does not apply to defects or damages caused by faulty installation or hook-up, abuse or misuse of the equipment including exposure to excessive heat, salt or fresh water spray, or water immersion except for equipment specifically designed as waterproof.
5. In case the equipment seems to be defective, the warranty holder (the "Claimant") must do the following to make a claim:
 - (a) Contact the dealer or service centre where the equipment was purchased and make the claim. Alternatively, the Claimant can make the claim to a dealer or service centre found at www.sleipnergrou.com. The Claimant must present a detailed written statement of the nature and circumstances of the defect, to the best of the Claimant's knowledge, including product identification and serial nbr., the date and place of purchase and the name and address of the installer. Proof of purchase date should be included with the claim, to verify that the warranty period has not expired;
 - (b) Make the equipment available for troubleshooting and repair, with direct and workable access, including dismantling of furnishings or similar, if any, either at the premises of the Warrantor or an authorised service representative approved by the Warrantor. Equipment can only be returned to the Warrantor or an authorised service representative for repair following a pre-approval by the Warrantor's Help Desk and if so, with the Return Authorisation Number visible postage/shipping prepaid and at the expense of the Claimant.
6. Examination and handling of the warranty claim:
 - (a) If upon the Warrantor's or authorised service Representative's examination, the defect is determined to result from defective material or workmanship in the warranty period, the equipment will be repaired or replaced at the Warrantor's option without charge, and returned to the Purchaser at the Warrantor's expense. If, on the other hand, the claim is determined to result from circumstances such as described in section 4 above or a result of wear and tear exceeding that for which the equipment is intended (e.g. commercial use of equipment intended for leisure use), the costs for the troubleshooting and repair shall be borne by the Claimant;
 - (b) No refund of the purchase price will be granted to the Claimant, unless the Warrantor is unable to remedy the defect after having a reasonable number of opportunities to do so. In the event that attempts to remedy the defect have failed, the Claimant may claim a refund of the purchase price, provided that the Claimant submits a statement in writing from a professional boating equipment supplier that the installation instructions of the Installation and Operation Manual have been complied with and that the defect remains.
7. Warranty service shall be performed only by the Warrantor, or an authorised service representative, and any attempt to remedy the defect by anyone else shall render this warranty void.
8. No other warranty is given beyond those described above, implied or otherwise, including any implied warranty of merchantability, fitness for a particular purpose other than the purpose for which the equipment is intended, and any other obligations on the part of the Warrantor or its employees and representatives.
9. There shall be no responsibility or liability whatsoever on the part of the Warrantor or its employees and representatives based on this Warranty for injury to any person or persons, or damage to property, loss of income or profit, or any other incidental, consequential or resulting damage or cost claimed to have been incurred through the use or sale of the equipment, including any possible failure or malfunction of the equipment or damages arising from collision with other vessels or objects.
10. This warranty gives you specific legal rights, and you may also have other rights which vary from country to country.

Patents

At Sleipner we continually reinvest to develop and offer the latest technology in marine advancements. To see the many unique designs we have patented visit our website www.sleipnergrou.com/patents

© Copyright Sleipner Motor AS, 2021

The information given in the document was correct at the time it was published.

However, Sleipner Motor AS can not accept liability for any inaccuracies or omissions it may contain. Continuous product improvement may change the product specifications without notice.

Therefore, Sleipner Motor AS can not accept liability for any possible differences between product and document.

Register your product and learn more at www.sleipnergroun.com



SLEIPNER AS

P.O. Box 519

N-1612 Fredrikstad

Norway

www.sleipnergroun.com

Made in Norway

